

Main Product Characteristics:

V_{DSS}	60V
$R_{DS(on)}$	2Ω (typ.)
I_D	0.27A

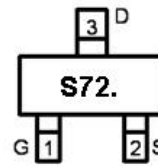
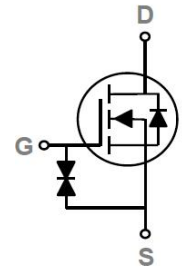

SOT-23

 Marking and pin
Assignments

Schematic Diagram

Features and Benefits:

- Advanced trench MOSFET process technology
- Special designed for PWM, load switching and general purpose applications
- Ultra low on-resistance with low gate charge
- High Power and current handing capability
- Fully Avalanche Rated
- ESD Protection HBM \geq 2KV

Description:

It utilizes the advanced trench processing techniques to achieve extremely low on resistance and low gate charge. These features combine to make this design an extremely efficient and reliable device for use in PWM, load switching and a wide variety of other applications.

Absolute Max Rating:

Symbol	Parameter	Max.	Units
$I_D @ T_C = 25^\circ\text{C}$	Continuous Drain Current, $V_{GS} @ 10\text{V}$ ①	0.27	A
$I_D @ T_C = 70^\circ\text{C}$	Continuous Drain Current, $V_{GS} @ 10\text{V}$ ①	0.22	
I_{DM}	Pulsed Drain Current ②	1.1	
$P_D @ T_C = 25^\circ\text{C}$	Power Dissipation ③	0.4	W
V_{DS}	Drain-Source Voltage	60	V
V_{GS}	Gate-to-Source Voltage	± 20	V
T_J	Operating Junction	-55 to + 150	$^\circ\text{C}$
T_{STG}	Storage Temperature Range	-55 to + 150	$^\circ\text{C}$

Thermal Resistance

Symbol	Characterizes	Typ.	Max.	Units
R _{θJA}	Junction-to-ambient (t ≤ 10s) ④	—	350	°C /W

Electrical Characteristics @T_A=25°C unless otherwise specified

Symbol	Parameter	Min.	Typ.	Max.	Units	Conditions
BV _{DSS}	Drain-to-Source breakdown voltage	60	—	—	V	V _{GS} = 0V, I _D = 250μA
R _{DS(on)}	Static Drain-to-Source on-resistance	—	2	3	Ω	V _{GS} =10V, I _D =500mA
		—	2.3	4		V _{GS} =4.5V, I _D = 200mA
		—	3.5	4.5		V _{GS} =3V, I _D =10mA
V _{GS(th)}	Gate threshold voltage	1	—	2.5	V	V _{DS} = V _{GS} , I _D = 250μA
I _{DSS}	Drain-to-Source leakage current	—	—	1	μA	V _{DS} =60V, V _{GS} = 0V
I _{GSS}	Gate-to-Source forward leakage	—	—	10	uA	V _{GS} =20V
	Gate-to-Source reverse leakage	—	—	-10		V _{GS} = -20V
Q _g	Total gate charge	—	1.2	—	nC	I _D = 200mA,
Q _{gs}	Gate-to-Source charge	—	1.8	—		V _{DS} =30V,
Q _{gd}	Gate-to-Drain("Miller") charge	—	0.2	—		V _{GS} = 4.5V
t _{d(on)}	Turn-on delay time	—	3.5	—	ns	V _{GS} =10V, V _{DS} =30V, R _{GEN} =10Ω, I _D =200mA
t _r	Rise time	—	21.5	—		
t _{d(off)}	Turn-Off delay time	—	5.8	—		
t _f	Fall time	—	21.2	—		
C _{iss}	Input capacitance	—	19.1	—	pF	V _{DS} =25V, V _{GS} =0V, f=1MHZ
C _{oss}	Output capacitance	—	12.8	—		
C _{rss}	Reverse transfer capacitance	—	6	—		

Source-Drain Ratings and Characteristics

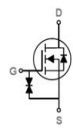
Symbol	Parameter	Min.	Typ.	Max.	Units	Conditions
I _S	Maximum Body-Diode Continuous Current	—	0.27	—	A	MOSFET symbol showing the integral reverse p-n junction diode. 
I _{SM}	Maximum Body-Diode Pulse Current	—	1.1	—	A	
V _{SD}	Diode Forward Voltage	—	0.86	1.3	V	T _J =25°C, I _S =200mA, V _{GS} =0V

Test Circuits and Wave forms

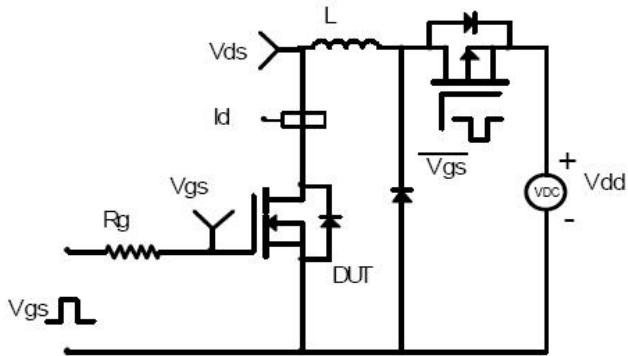
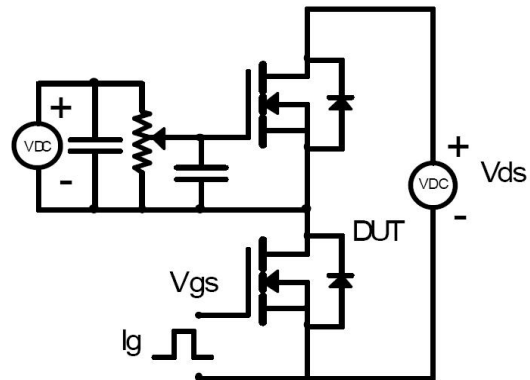
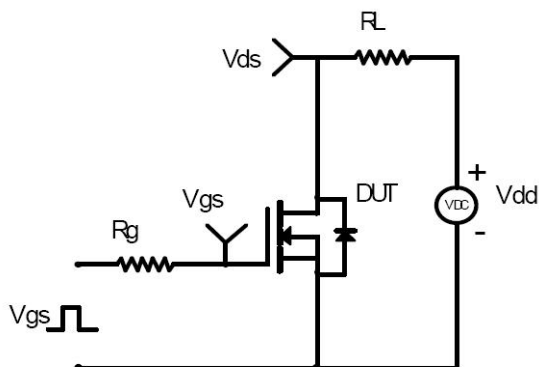
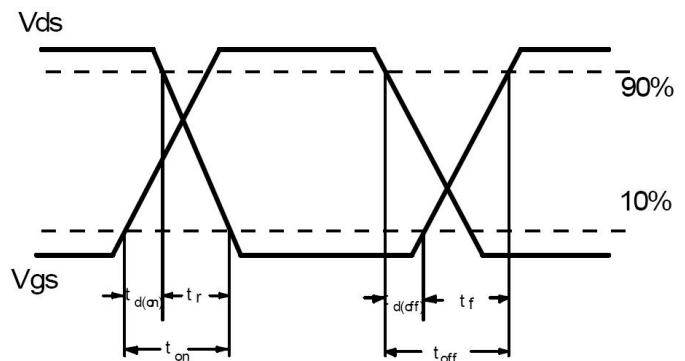
EAS Test Circuit:

Gate Charge Test Circuit:

Switching Time Test Circuit:

Switching Waveforms:

Notes:

- ① Calculated continuous current based on maximum allowable junction temperature.
- ② Repetitive rating; pulse width limited by max. junction temperature.
- ③ The power dissipation P_D is based on max. junction temperature, using junction-to-case thermal resistance.
- ④ The value of $R_{\theta JA}$ is measured with the device mounted on 1 in 2 FR-4 board with 2oz. Copper, in a still air environment with $T_A = 25^\circ\text{C}$

Typical electrical and thermal characteristics

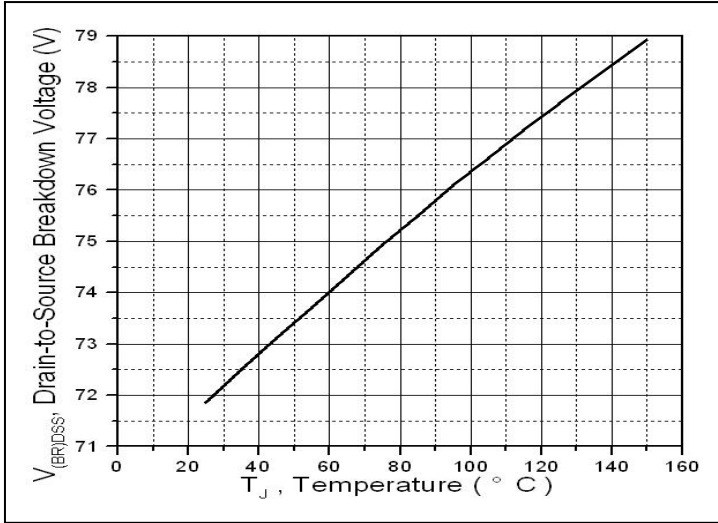

Figure 1. Drain-Source Breakdown Voltage

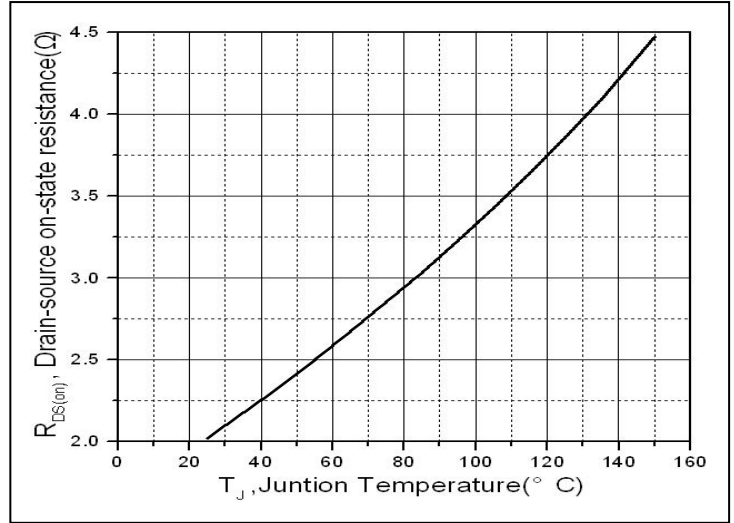

Figure 2. Normalized On-Resistance vs. Junction Temperature

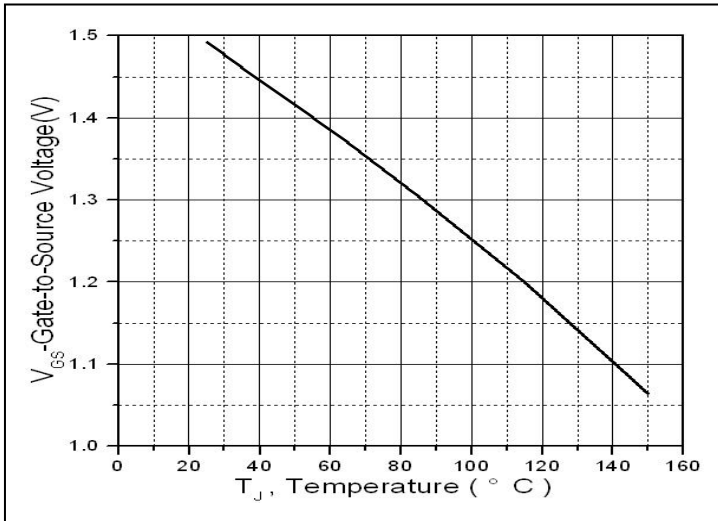

Figure 3. Gate to source cut-off voltage vs. Junction Temperature

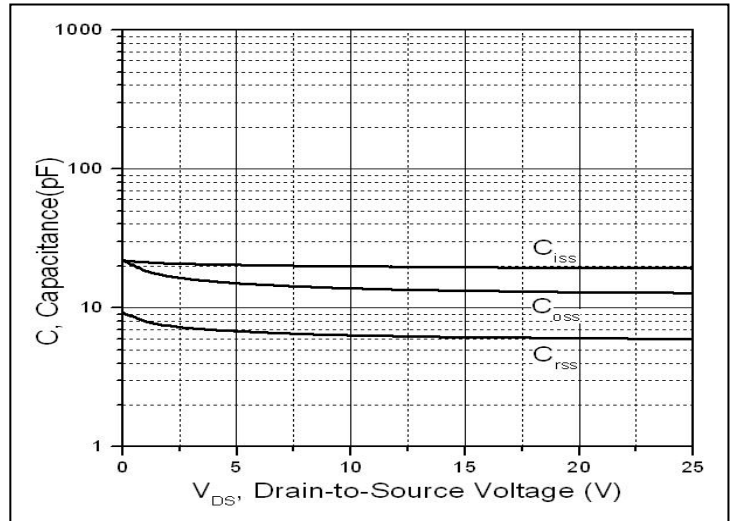

Figure 4. Typical Capacitance vs. Drain-to-Source Voltage

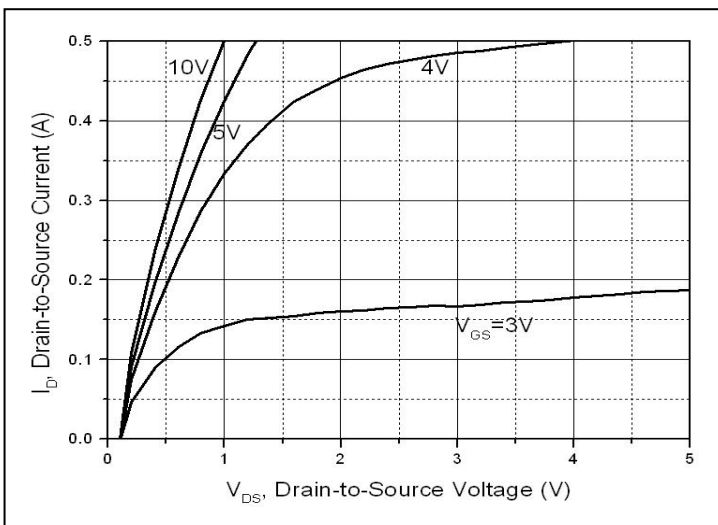
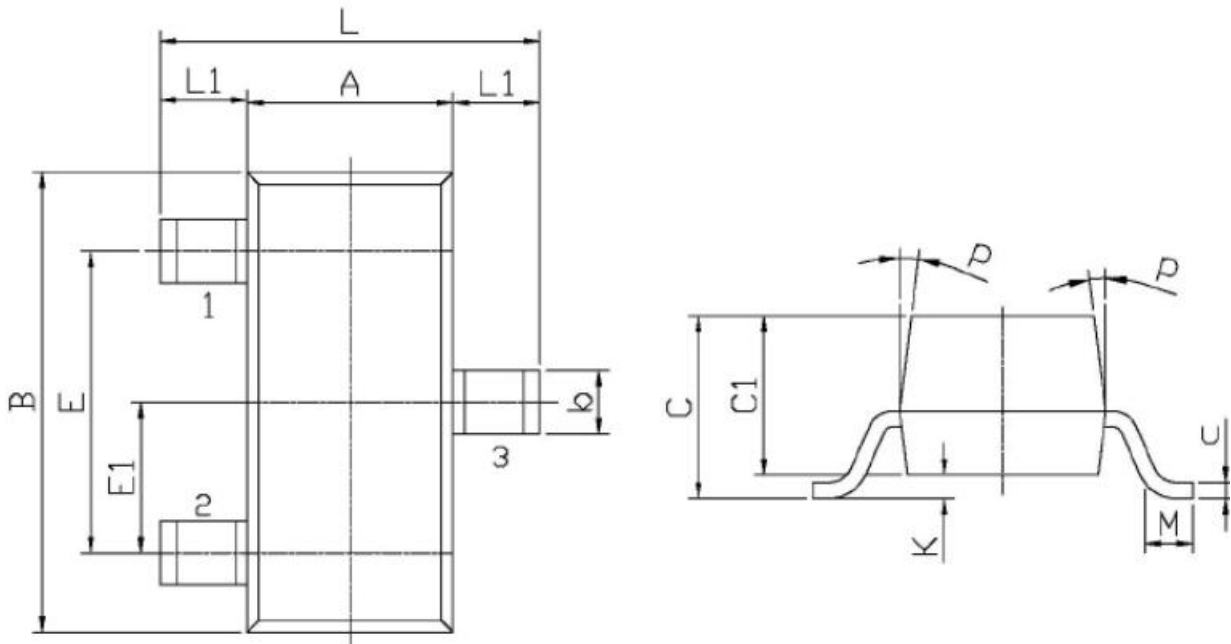

Figure 5. Typical Output Characteristics

Mechanical Data:

单位: mm



Symbol	Dimensions In Millimeters		Symbol	Dimensions In Millimeters	
	Min	Max		Min	Max
L	2.2	2.7	C	1.30Max	
L1	0.45	0.65	C1	0.90	1.20
A	1.15	1.50	c	0.05	0.20
B	2.70	3.10	K	0	0.10
E	1.70	2.10	M	0.20MIN	
E1	0.85	1.05	P	7°	
b	0.35	0.55			

ATTENTION:

- Any and all Silikron products described or contained herein do not have specifications that can handle applications that require extremely high levels of reliability, such as life-support systems, aircraft's control systems, or other applications whose failure can be reasonably expected to result in serious physical and/or material damage. Consult with your Silikron representative nearest you before using any Silikron products described or contained herein in such applications.
- Silikron assumes no responsibility for equipment failures that result from using products at values that exceed, even momentarily, rated values (such as maximum ratings, operating condition ranges, or other parameters) listed in products specifications of any and all Silikron products described or contained herein.
- Specifications of any and all Silikron products described or contained herein stipulate the performance, characteristics, and functions of the described products in the independent state, and are not guarantees of the performance, characteristics, and functions of the described products as mounted in the customer's products or equipment. To verify symptoms and states that cannot be evaluated in an independent device, the customer should always evaluate and test devices mounted in the customer's products or equipment.
- Silikron Microelectronics (Suzhou) Co.,Ltd. strives to supply high-quality high-reliability products. However, any and all semiconductor products fail with some probability. It is possible that these probabilistic failures could give rise to accidents or events that could endanger human lives, that could give rise to smoke or fire, or that could cause damage to other property. When designing equipment, adopt safety measures so that these kinds of accidents or events cannot occur. Such measures include but are not limited to protective circuits and error prevention circuits for safe design, redundant design, and structural design.
- In the event that any or all Silikron products(including technical data, services) described or contained herein are controlled under any of applicable local export control laws and regulations, such products must not be exported without obtaining the export license from the authorities concerned in accordance with the above law.
- No part of this publication may be reproduced or transmitted in any form or by any means, electronic or mechanical, including photocopying and recording, or any information storage or retrieval system, or otherwise, without the prior written permission of Silikron Microelectronics (Suzhou) Co.,Ltd.
- Information (including circuit diagrams and circuit parameters) herein is for example only ; it is not guaranteed for volume production. Silikron believes information herein is accurate and reliable, but no guarantees are made or implied regarding its use or any infringements of intellectual property rights or other rights of third parties.
- Any and all information described or contained herein are subject to change without notice due to product/technology improvement, etc. When designing equipment, refer to the "Delivery Specification" for the Silikron product that you intend to use.